

NOTE

This manual is for two models, which are distinguished by **model A** and **model B** in this manual.

Please note **model A** has no temperature measurement function, while **model B** has no diode test function. You can judge which model you have from this.

CONTENTS

1. SAFETY INFORMATION.....	1
2. MAINTENANCE.....	4
3. CALMP METER LAYOUT.....	5
4. OPERATING INSTRUCTION.....	8
5. SPECIFICATIONS.....	12
6. REPLACING THE BATTERY.....	15
7. ACCESSORIES.....	17
CAUTION.....	17

1. SAFETY INFORMATION

This digital clamp meter has been designed according to IEC1010- 1 and IEC1010-2-032 concerning safety requirements for electrical measuring instruments and hand – held current clamps with overvoltage category 1000V CAT II 600V CAT III and pollution 2.

1.1 SAFETY SYMBOLS

 Important safety information, refer to the operating manual.

 Dangerous voltage may be present.

 Earth ground.

 Double insulation (Protection class 1000V CAT II 600V CAT III).

The digital clamp meter complies with the requirements of the following European Community Directives: 89/336/EEC (Electromagnetic Compatibility) and 73/23/EEC (Low Voltage) as amended by 93/68/EEC (CE

Marking).

However, electrical noise or intense electromagnetic fields in the vicinity of the equipment may disturb the measurement circuit. Measuring instruments will also respond to unwanted signals that may be present within the measurement circuit.

Users should exercise care and take appropriate precautions to avoid misleading.

1.2 SAFETY PRECAUTIONS

Follow all safety and operating instructions to ensure maximum personal safety during the operation and to ensure the meter is used safely and is kept in good operating condition.

- Read these operating instructions thoroughly and completely before operating your meter. Pay particular attention to WARNINGS, which will inform you of potentially dangerous procedures. The instructions in these warnings must be

followed.

- Always inspect your meter and test leads for any sign of damage or abnormality before every use. If any abnormal conditions exist (i.e. broken test leads, cracked cases, display not reading, etc.), do not attempt to take any measurements.
- Do not expose the instrument to direct sunlight, extreme temperature or moisture.
- Never ground yourself when taking electrical measurements. Do not touch exposed metal pipes, outlets, fixtures, etc., which might be at ground potential. Keep your body isolated from ground by using dry clothing; rubber shoes, rubber mat, or any approved insulating material.
- You always are careful when working with voltages above 60V dc or 30V ac rms. Keep fingers behind the probe barriers while measuring.
- Never use the meter to measure voltages that might exceed the maximum allowable input value

of any function.

- Never touch exposed wiring, connections or any live circuit when attempting to take measurements.

2. MAINTENANCE

- Before opening the case, always disconnect test leads from all energized circuits.
- Never use the meter unless the back cover is in place and fastened completely.
- Do not use abrasives or solvents on the meter. To clean it using a damp cloth and mild detergent only.
- Qualified and trained service technicians should only perform calibration and repair of the meter.
- Do not attempt calibration or service unless trained and another person capable of rendering first aid and resuscitation is present.

3. CLAMP METER LAYOUT

The meter is a handheld 3 1/2 digital clamp meter for measuring DC and AC voltage, AC current, Resistance, Diode and Continuity Test etc with battery operated.

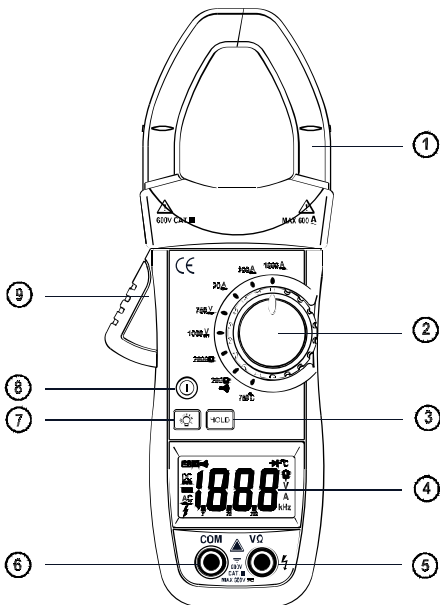

① Transformer jaws

Pick up the AC current flowing through the conductor.

② Rotary switch

This switch is used to select functions and desired ranges.

③ Hold button

When this button is pushed, the display will keep the last reading and “” symbol will appear on the LCD until pushing it again.

④ Display

3 1/2 digit, 7 segment, 16mm high, LCD.

⑤ V/ Ω jack

This is positive input terminal for volt, resistance, diode, temperature and Continuity test.

Connection is made to it using the red test lead.

⑥ “COM” jack

This is negative (ground) input terminal for all measurement modes except current. Connection is made to it using the black test lead.

⑦ Back light

To use this function, press the LIGHT button. When this button is pushed, the Back light of display is on. After about 3 – 5 seconds, the Back light is self-off. The Back light is on again, just push this button once.

⑧ Power Switch

A push – push switch is used to turn the meter on or off.

⑨ Trigger

Press the lever to open the transformer jaws.

When the lever is released, the jaws will close again.

4. OPERATING INSTRUCTIONS

4.1 DC VOLTAGE MEASUREMENT

1. Connect the red test lead to the “V/ Ω ” jack and the black lead to the “COM” jack.
2. Set rotary switch at desired 1000V $\overline{\text{---}}$ position.
3. Connect test leads across the source or load being measured.
4. Read voltage value on the LCD display along with the polarity of the red lead connection.

4.2 AC VOLTAGE MEASUREMENT

1. Connect the red test lead to “V/ Ω ” jack and the black test lead to the “COM” jack.
2. Set the rotary switch at desired 750V~ position.
3. Connect test leads across the source or load

being measured.

4. Read voltage value on the LCD display.

4.3 AC CURRENT MEASUREMENT

1. Set the rotary switch at desired A~ position.
2. Press the trigger to open transformer jaw and to clamp one conductor only, making sure that the jaw is firmly closed around the conductor.
3. Read current value on LCD display.
4. When only the figure "1" is displayed, it indicates overrange situation and the higher range has to be selected.

4.4 RESISTANCE MEASUREMENT

1. Connect the red test lead to "V/ Ω " jack and black test lead to the "COM" jack (The polarity of red lead is positive "+").
2. Set the rotary switch at desired " Ω " range position.
3. Connect test leads across the resistor to be

measured and read LCD display.

4. If the resistance being measured is connected to a circuit, turn off power and discharge all capacitors before applying test probes.

NOTE:

1. If the resistance being measured exceeds the maximum value of the range selected or the input is not connected, an overrange indication “1” will be displayed.

2. When checking in-circuit resistance, be sure the circuit under test has all power removed and that all capacitors have been discharged fully.

4.5 AUDIBLE CONTINUITY TEST

1. Connect red test lead to “V/ Ω ” jack, black test lead to “COM” jack.

2. Set range switch to “•||” position.

3. Connect test leads to two points of circuit to be tested. If continuity exists, built-in buzzer will sound.

4.6 MEASURING TEMPERATURE (Model B)

1. Set the rotary switch at 750°C position.
2. Connect the red lead of “K” type thermocouple into the “V/Ω” jack and the black lead of “K” type thermocouple into the “COM” jack. The LCD display will show the current environment temperature.
3. Contacting the object be measured with the thermocouple probe.
4. Read temperature value on the LCD display.

4.7 DIODE TEST (Model A)

1. Connect the red test lead to “V/Ω” jack and the black test lead to the “COM” jack (The polarity of red lead is positive “+”).
2. Set the rotary switch at “” position.
3. Connect the red test lead to the anode of the diode to be tested and the black test lead to the cathode of the diode.

The approx. forward voltage drop of the diode will

be displayed. If the connection is reversed, only figure “1” will be shown.

5. SPECIFICATIONS

Accuracy is specified for a period of one year after calibration and at 18°C to 28°C (64°F to 82°F) with relative humidity to 80%.

5.1 GENERAL

Maximum voltage between terminals and earth ground: *CAT II 1000V and CAT III 600V*

Display: *LCD, 1999 counts, updates 2-3/sec.*

Polarity indication: *“-” displayed for negative polarity.*

Over range indication: *Only figure “1” on the display.*

Jaw opening capability: *42mm (Max conductor size)*

Power: *4.5V (3×1.5V AAA)*

Low battery indication: *“ ” appears on the*

display.

Operating temperature: 0°C to 40°C .

Storage temperature: -10°C to 50°C

Altitude: 2000m

Size: 225mm×86mm×32mm

Weight: *Approx.* 330g

5.2 DC Voltage

Range	Resolution	Accuracy
1000V	1V	$\pm 1.0\%$ of rdg ± 2 digits

Input Impedance: 10M Ω

5.3 AC Voltage

Range	Resolution	Accuracy
750V	1V	$\pm 1.2\%$ of rdg ± 5 digits

Input Impedance: 10M Ω

Frequency range: 40Hz to 400Hz. Response:

Average responding, calibrated in rms. of a sine wave.

Max. input voltage: 1000V DC or 750V AC RMS.

5.4 AC Current

Range	Resolution	Accuracy
20A	0.01A	$\pm 2.0\%$ of rdg ± 5 digits
200A	0.1A	$\pm 2.0\%$ of rdg ± 5 digits
1000A	1A	$\pm 2.5\%$ of rdg ± 7 digits

Overload Protection: 1200A for 60 seconds maximum.

Frequency range: 50Hz to 60Hz.

5.5 Resistance

Range	Resolution	Accuracy
200 Ω	0.1 Ω	$\pm 1.0\%$ of rdg ± 3 digits
2000 Ω	1 Ω	$\pm 1.0\%$ of rdg ± 3 digits

5.6 Continuity

Range	Description
•))	If continuity exists (about less than 20 Ω), built-in buzzer will sound.

5.7 Temperature (Model B)

Range	Resolution	Accuracy
400~750°C	1°C	±1.0% of rdg ± 5 digits
0~400°C	1°C	±1.0% of rdg ± 3 digits
-40~0°C	1°C	±1.0% of rdg ± 6 digits

5.8 Diode

Range	Function
	Display: read approximate forward voltage of diode

6. REPLACING THE BATTERY

WARNING!

Before attempting to open the case of battery, always be sure that test leads have been disconnected from measurement circuits. Close case and tighten screws completely before using the meter to avoid electrical shock hazard.

If “” appears on display, it indicates that the battery should be replaced. Use the following procedure to replacing the battery:

1. Disconnect test leads from any live source and remove the test leads from the input terminals of the meter. Push the POWER switch to OFF,
2. The battery cover is secured to the bottom case by a screw. Using a screwdriver, remove the screw from the battery cover and remove the battery cover.
3. Remove battery and replace with a new equivalent 9 volt battery.
4. Replace the battery cover and reinstall the screw.

7. ACCESSORIES

- Operator's instruction manual
- Set of test leads
- "K" type thermocouple (Only model B)
- Gift box
- Batteries: 3×1.5V AAA

CAUTION:

Using this appliance in an environment with a strong radiated radio-frequency electromagnetic field (approximately 3V/m), may influence its measuring accuracy.

The measuring result can be strongly deviating from the actual value.